



Standard Test Method for Annealing Point and Strain Point of Glass by Beam Bending¹

This standard is issued under the fixed designation C598; the number immediately following the designation indicates the year of original adoption or, in the case of revision, the year of last revision. A number in parentheses indicates the year of last reapproval. A superscript epsilon (ϵ) indicates an editorial change since the last revision or reapproval.

1. Scope

1.1 This test method covers the determination of the annealing point and the strain point of a glass by measuring the rate of midpoint viscous bending of a simply loaded glass beam.² However, at temperatures corresponding to the annealing and strain points, the viscosity of glass is highly time-dependent. Hence, any viscosities that might be derived or inferred from measurements by this procedure cannot be assumed to represent equilibrium structural conditions.

1.2 The annealing and strain points shall be obtained following a specified procedure after direct calibration of the apparatus using beams of standard glasses having known annealing and strain points such as those supplied and certified by the National Institute of Standards and Technology.³

1.3 This test method, as an alternative to Test Method C336 is particularly well suited for glasses that for one reason or another are not adaptable for flame working. It also has the advantages that thermal expansion and effective length corrections, common to the fiber elongation method, are eliminated.

1.4 The values stated in metric units are to be regarded as the standard. The values given in parentheses are for information only.

1.5 *This standard does not purport to address all of the safety concerns, if any, associated with its use. It is the responsibility of the user of this standard to establish appropriate safety and health practices and determine the applicability of regulatory limitations prior to use.*

¹ This test method is under the jurisdiction of ASTM Committee C14 on Glass and Glass Products and is the direct responsibility of Subcommittee C14.04 on Physical and Mechanical Properties.

Current edition approved Oct. 1, 2013. Published October 2013. Originally approved in 1967. Last previous edition approved in 2008 as C598 – 93 (2008). DOI: 10.1520/C0598-93R13.

² Hagi, H. E., "Experimental Evaluation of Beam Bending Method of Determining Glass Viscosities in the Range 10^8 to 10^{15} Poises," *Journal of the American Ceramic Society*, Vol 46, No. 2, 1963, pp. 95–97.

³ NIST Special Publication 260.

2. Referenced Documents

2.1 *ASTM Standards*:⁴

C336 Test Method for Annealing Point and Strain Point of Glass by Fiber Elongation

3. Terminology

3.1 *Definitions*:

3.1.1 *annealing range*—the range of glass temperature in which stresses in glass articles can be relieved at a commercially desirable rate. For purposes of comparing glasses, the annealing range is assumed to correspond with the temperatures between the annealing point (A. P.) and the strain point (St. P.).

3.1.2 *annealing point*—that temperature at which internal stresses in a glass are substantially relieved in a matter of minutes. During a test in accordance with the requirements of this test method, the midpoint rate of viscous deflection of the test beam is measured by an extensometer with suitable magnification during cooling at a rate of $4 \pm 1^\circ\text{C}/\text{min}$. The nominal deflection rate at the annealing point ideally is as follows:

$$\text{Deflection rate, cm/min} = (2.67 \times 10^{-11} L^3 M) / I_c \quad (1)$$

where:

L = support span, cm;

M = centrally applied load, g; and

I_c = cross-section moment of inertia of test beam, cm^4 (see Appendix X1).

3.1.3 *strain point*—that temperature at which internal stresses in a glass are substantially relieved in a matter of hours. The strain point is determined by extrapolation of the annealing point data and is the temperature at which the viscous deflection rate is 0.0316 times that observed at the annealing point.

⁴ For referenced ASTM standards, visit the ASTM website, www.astm.org, or contact ASTM Customer Service at service@astm.org. For *Annual Book of ASTM Standards* volume information, refer to the standard's Document Summary page on the ASTM website.

4. Significance and Use

4.1 This test method offers an alternate procedure to Test Method C336 for determining the annealing and strain points of glass. It is particularly recommended for glasses not adaptable to flame working. Also fewer corrections are necessary in data reduction.

5. Apparatus

5.1 The apparatus shall consist of a furnace, a means of controlling its temperature and cooling rate, a specimen holder and loading rod, and a means of observing the rate of midpoint viscous deflection of the glass beam.

5.1.1 *Furnace*—The furnace shall be electrically heated by resistance-wire windings of either platinum-rhodium or 80-20 Ni-Cr alloys. A cutaway drawing of a typical furnace is shown in Fig. 1. Dimensions and details of the furnace construction are not critical, but a cylindrical furnace of height of 255 mm (10 in.), outside diameter of 230 mm (9 in.), and inside diameter of 130 mm (5 in.) with a removable top plug is recommended. The temperature distribution shall be such that differences in temperature greater than 2°C shall not result over

the length of the specimen beam and along the axis of the furnace from the undeflected beam plane to a point 13 mm (½ in.) below.

5.1.2 *Temperature Measuring and Indicating Instruments*—For the measurement of temperature, there shall be provided a calibrated Type R or S thermocouple. The thermocouple shall be housed in a double-bore alumina tube with its junction placed within 5 mm of the specimen near the axis of the furnace. It is recommended that the thermocouple be referenced to 0°C by means of an ice bath and its emf measured with a calibrated potentiometer having a sensitivity of ±1 μV and an accuracy of ±5 μV. Precautions shall be taken to ensure that the ice bath is maintained at 0°C throughout the test.

5.1.3 *Furnace Control*—Suitable means shall be provided for idling the furnace, controlling the heating rate, and, in the case of very hard glasses, limiting the cooling rate to not more than 5°C/min. Although commercially available programming equipment provides excellent control, a variable transformer with manual control is an inexpensive and adequate technique.

5.1.4 *Specimen Holder and Loading Rod*—A ceramic support stand and a ceramic loading rod shall be provided for

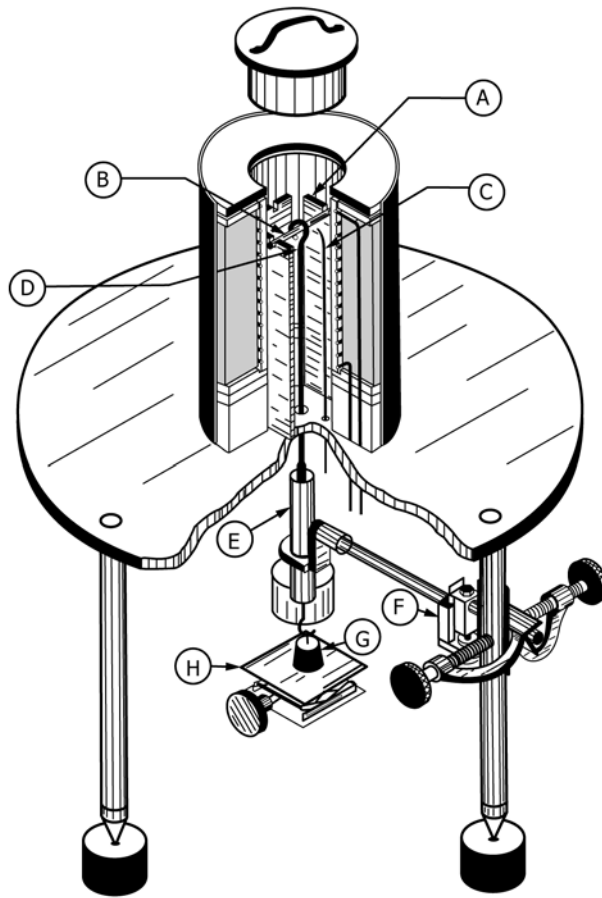

A—Alumina muffle support stand
 B—Specimen beam
 C—Thermocouple
 D—Loading rod

E—Linearly variable differential transformer (LVDT)
 F—Zero-adjust mechanism for LVDT
 G—Weight
 H—Laboratory jack

FIG. 1 Cutaway Drawing of Beam-Bending Apparatus